

SAILOR 6018 Message Terminal

Installation guide

What's in the box?

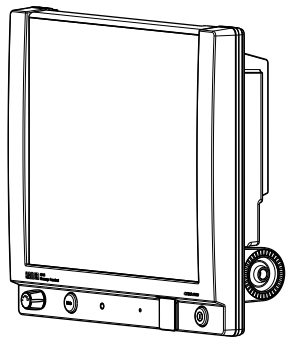

SAILOR 6018 Message Terminal

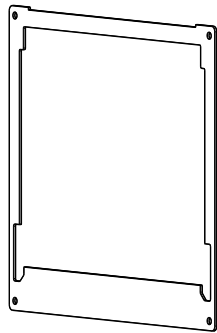

Flush Mounting Gasket



Installation Guide

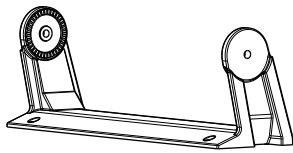

U-Mounting Bracket



Wheel Knob
(2 pcs.)

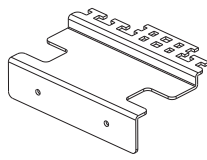

Cable Relief Plate



Power Cable,
2.5 m



Screw M4x12
TORX 20
(5 pcs.)



Screw ø3.9x19
TORX 20
(5 pcs.)



Screw M3x8
Countersink
(3 pcs.)

Dimensions

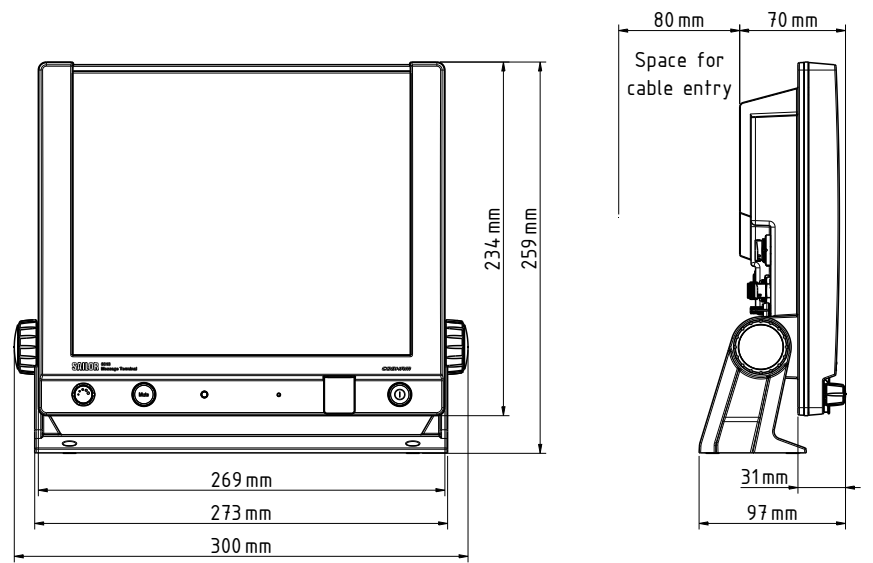

How to install on the desktop

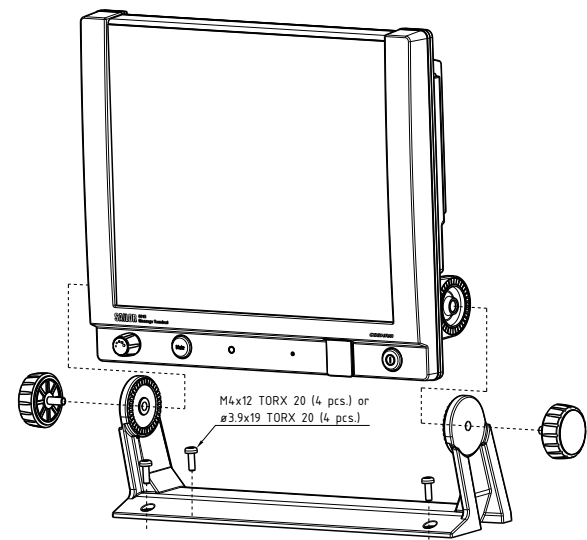

How to install for flush mounting

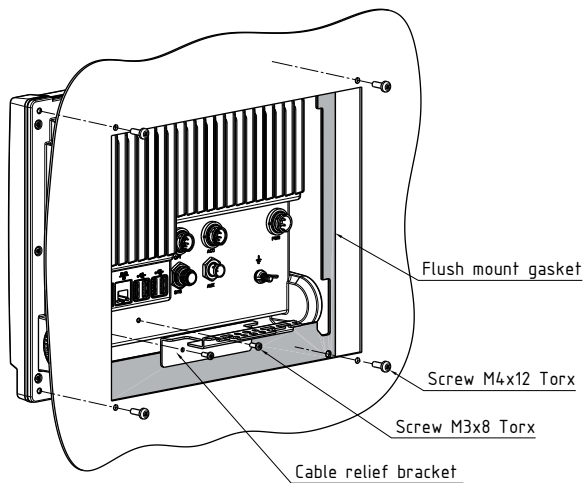

Drilling plan on the desktop

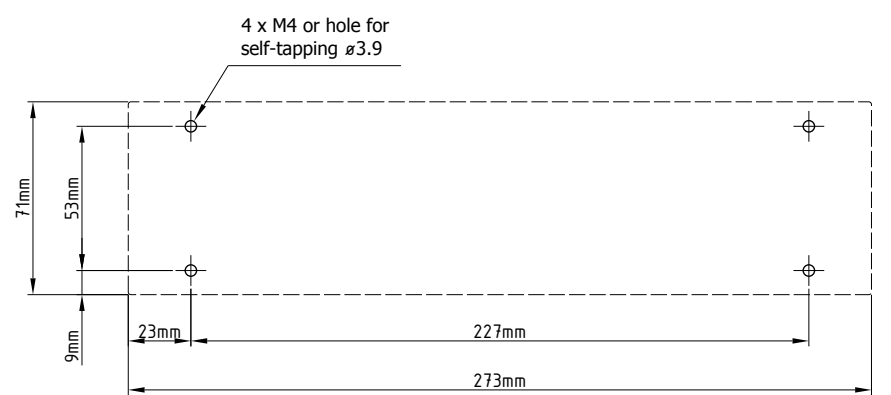

Cutout for flush mounting

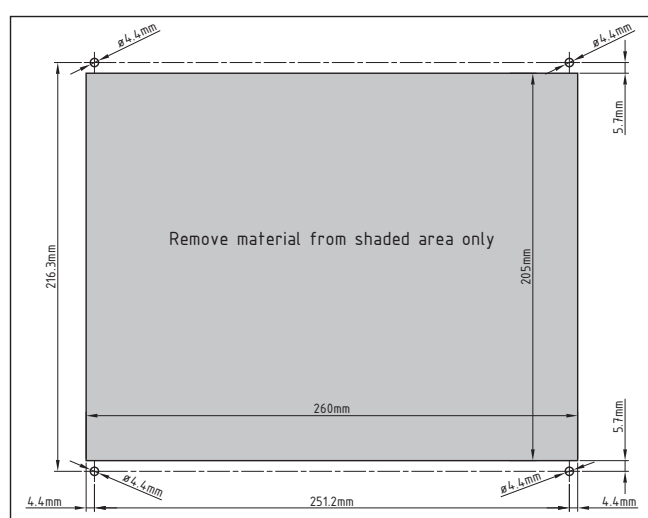

For cut-out you may use the drawing scaled 1:1 on the back page.

Connections

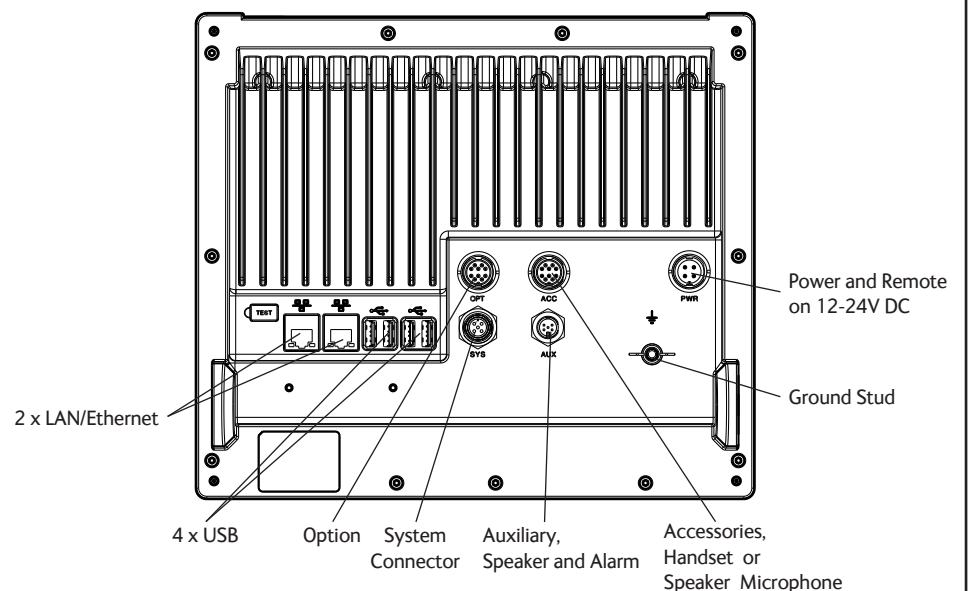

For further information, download the installation manual 98-150478 at www.cobham/satcom

Cutout for flush mounting - Scale 1:1

Remove material from shaded area only

IMPORTANT!

If this template was printed from an electronic file or copied, scaling (1:1) may not be correct. Consequently do not attempt to use a printed or copied template without prior checking of dimensions.

System Configuration - Example

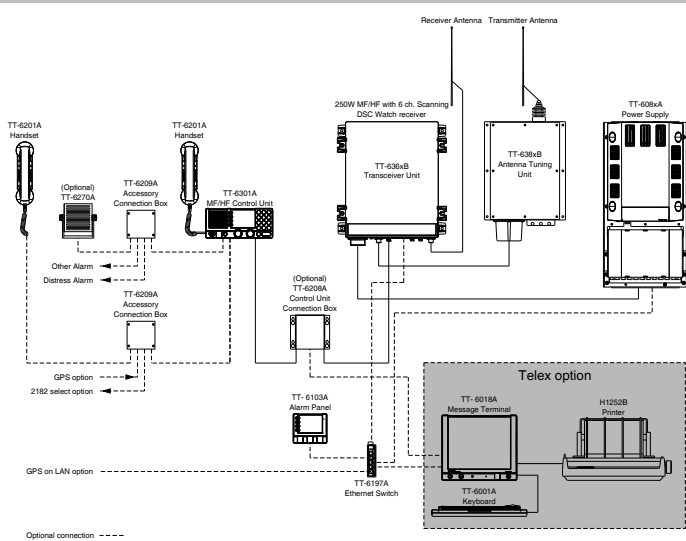

Disclaimer

Any responsibility or liability for loss or damage in connection with the use of this product and the accompanying documentation is disclaimed by Thrane & Thrane A/S. The information in this manual is provided for information purposes only, is subject to change without notice and may contain errors or inaccuracies. Manuals issued by Thrane & Thrane A/S are periodically revised and updated. Anyone relying on this information should acquire the most current version e.g. from www.cobham.com/communications-and-connectivity/satcom, **Service and support**, or from the distributor. Thrane & Thrane A/S is not responsible for the content or accuracy of any translations or reproductions, in whole or in part, of this manual from any other source. In the event of any discrepancies, the English version shall be the governing text.

Thrane & Thrane A/S is trading as Cobham SATCOM.

Power Cable - Connections

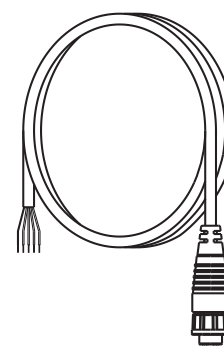

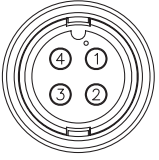
Description	Pin	Wire color	Pin assignments Front view 
12-24V DC+	1	Red	
12-24V DC-	2	Black	
Remote on_in (Can be connected through a switch to ground)	3	White	
On_out (Can be connected to compatible equipment with remote on_in)	4	Blue	
Outer shield must be connected to ground	Shield		